

# 48-T100 Multi-Function Timer



## ORDERING CODE



## Application Examples

- Delayed energisation of loads on power-up.
- Switching loads on and off repetitively in equal intervals.
- Delayed release after limit switch operation.
- Off delay timer in conveyor and numerous similar applications.
- Energisation of loads for a set period of time.
- Alternating operation of two loads in equal intervals.
- Sequential switching of loads.

## Features

- Power supply ordering options: 100 to 230V AC, 24V AC/DC or 12V DC.
- Six programmable timing functions.
- Separate Start, Reset and Gate inputs.
- Polarity protection on inputs.
- Extra short housing.
- DPDT relay supplied as standard (5A per contact)
- Microprocessor technology based.
- High repetitive and setting accuracy.
- Automatic (i.e. power up) pulse or hold start.
- Power ON and Relay ON LED's.
- Front dial can be used as a screwdriver for adjusting the operational settings.
- Flashing Power ON LED when unit is timing (flash rate increases when relay is about to switch).

The 48-T100 is a fully programmable, microprocessor based multi-function timer, incorporating 6 overlapping time ranges within 0.1 second to 100 hours. The unit has independent Start, Reset and Gate inputs which can be individually activated by connecting each selected input pin to pin 2 (common).

Before operation, the timer can be programmed to operate in any of the following modes:

**A: Delayed ON Operation, Pulse Start:** At power up the relay is de-energised. Timing only commences on activation of the start input. After the set time expires, the relay energises. The relay remains energised until either the reset input is activated or the power supply is interrupted for more than 0.1 second.

**B1: Symmetrical Recycling, First Cycle OFF Operation:** At power up, the relay is de-energised. On activation of the start input, the relay will switch on and off repetitively starting with the OFF cycle. The relay de-energises and/or remains de-energised if either the reset input is activated or power supply is interrupted for at least 0.1second. The duration of the ON cycle and the OFF cycle are both equal to the set time.

**B2: Symmetrical Recycling, First Cycle ON Operation:** At power up, the relay is de-energised. On activation of the start input, the relay will switch on and off repetitively, starting with the ON cycle. The relay de-energises and/or remains de-energised if either the reset input is activated or power supply is interrupted for at least 0.1 second. The duration of the ON cycle and the OFF cycle are both equal to the set time.

**C: Signal ON/OFF Delay:** At power up the relay is de-energised. On activation of the start input, the relay energises and timing commences. After the set time

expires, the relay de-energises. On release of the start input, the relay energises and timing commences again. After the set time expires, the relay de-energises again.

**D: Interval Operation, Hold Start:** At power up the relay is de-energised. On activation of the start input, the relay energises. Timing will only commence on the release of the start input. After the set time expires, the relay de-energises.

**E: Interval Operation, Pulse Start:** At power up the relay is de-energised. On activation of the start input, the relay energises and timing commences. After the set time expires, the relay de-energises. When the start input is re-activated, the relay once again energises and the timing cycle begins.

**Gate Input:** When the Gate Input is activated, the unit stops timing. Timing only resumes once the Gate Input is released. The set time is thus extended by the time the Gate Input is activated. Gate input acts as a stop clock or pause button.

Notes:

1. If the start-input pin 6 is linked permanently to pin 2, the unit will start timing immediately on power up.
2. Start, Reset and Gate inputs must be activated via potential-free contacts between the relevant input pin and pin 2 (common).
3. The Start, Reset and Gate inputs are all electronically protected (i.e.: connection of any one of the input pins to pin 10 will not damage the unit).
4. Function Test Mode is achieved by adjusting the dial fully anti-clockwise. This will result in the unit performing the set function with a time base (t) = 5 sec.

Function A: Delay ON Operation

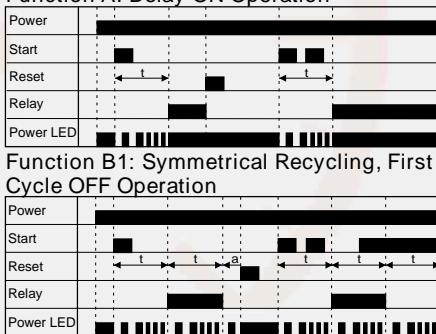

t = Preset time

Function B2: Symmetrical Recycling, First Cycle ON Operation

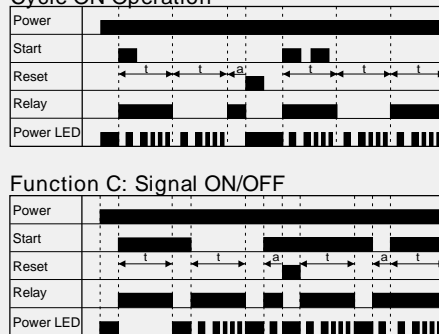

a = a < t

Function D: Interval Operation

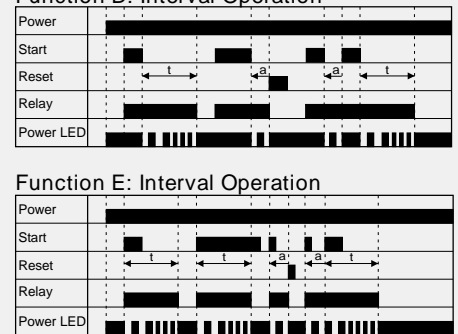

Gate Input= Acts as a Stop Clock or Pause Button.

Function C: Signal ON/OFF

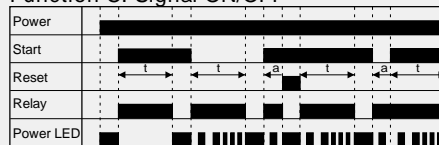

Function E: Interval Operation

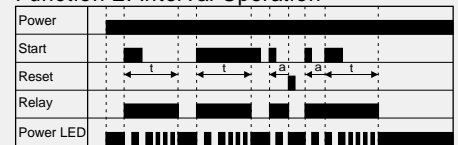

## Description of Controls

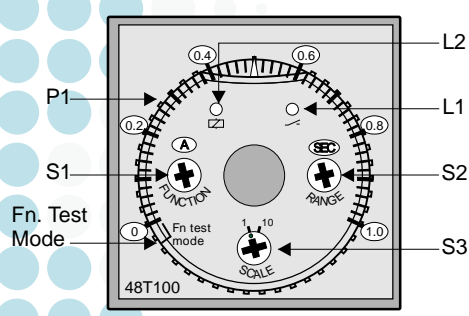

See page ?? for Dimensional Diagram.

- L1: The red "RELAY ON" LED illuminates when the relay is energised.
  - L2: The green "POWER ON" LED illuminates when power is supplied to the unit. This LED flashes when the unit is timing. The flash rates increase just before the relay switches.
  - S1: The Time Function is set on S1.  
 Position A: Delayed ON Operation, Pulse Start  
 Position B1: Symmetrical Recycling, OFF Cycle First  
 Position B2: Symmetrical Recycling, ON Cycle First  
 Position C: Signal ON/OFF Delay  
 Position D: Interval Operation, Hold Start  
 Position E: Interval Operation, Pulse Start
  - S2: The Time Range is set on S2. The 4 available time settings are SECONDS, MINUTES, HOURS and 10 HOURS.
  - S3: Two dial scales are selectable on S3.  
 Position 1 adjusts the scale to have a range from 0 to 1.  
 Position 10 adjusts the scale to have a range from 0 to 10.
  - P1: The Time Setting is adjusted on P1.
- Fn Test Mode: When the dial, P1 is adjusted fully anticlock-wise, the unit will perform the set function with a time base (t) = 5 sec.

## Wiring and Connection

### Relay Contacts-DPDT

CONTACT1	Normally Open	1 + 3
	Normally Closed	1 + 4
CONTACT2	Normally Open	11 + 9
	Normally Closed	11 + 8

### Power Supply

Phase/Positive	10
Neutral/Negative	2

### Input

Start	6
Reset	7
Gate	5
Common	2

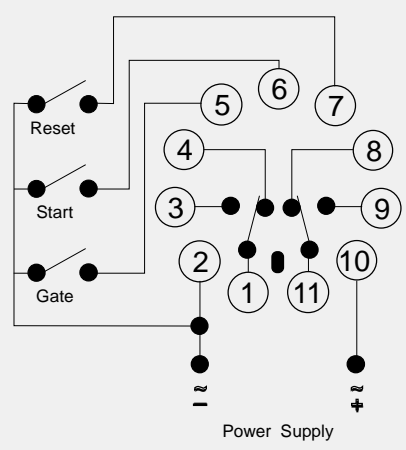

Note: The positions of the relay contacts are shown in the de-energised state.

## Technical Specifications

Power Supply			
Supply Voltage	100 to 230VAC	24 VAC/DC	12VDC
Power Consumption	3 VA	2 VA (AC) 1W (DC)	1.5W
Supply Tolerance	±10%	±10%	±10%
Power Reset		100 msec minimum	

General Specifications	
Relay Contacts	2 x 5A @ 250VAC
Standards	CE Rated
Enclosure Protection Rating	IP40
Weight	100gm (approximately)

Start, Reset and Gate Inputs	
Start Activation	On connecting pin 6 to pin 2
Reset Activation	On connecting pin 7 to pin 2
Gate Activation	On connecting pin 5 to pin 2
Input Protection	Connecting input pins to pin 10 instead of pin 2 will not damage the unit. However the input will not be recognised by the unit.
Input Signal	50 msec minimum

Time Specification	
Setting Accuracy	Maximum of ±5% full scale ±50msec
Repeatability	Maximum of ±0.3% of full scale ±10msec (in 1 sec time range)
Temperature Influence	Maximum of ±2% of full scale
Influence of Supply Voltage Variance	Maximum of ±0.5% of full scale ±10msec (in 1 sec time range)
Power Reset Time	100msec minimum
Input Reset Time	50msec minimum

Settings		
Time Setting	Scale Setting	
	1	10
Sec	0.1 sec to 1 sec	1 sec to 10 sec
Min	0.1 min to 1 min	1 min to 10 min
Hrs	0.1 hr to 1 hr	1 hr to 10 hrs
10 Hrs	1 hr to 10 hrs	10 hrs to 100 hrs

Note: Function Test Mode is achieved by adjusting the dial fully anti-clockwise. This will result in the unit performing the set function with a time base (t) = 5 sec.